

# PRELIMINARY PRODUCT REVIEW

Rev 0; 6/05



## Microcontroller with Internal Voltage Regulator, Piezoelectric Horn Driver, and Comparator

MAXQ3210

### General Description

The MAXQ3210 microcontroller is a low-power, 16-bit RISC device that incorporates a driver for a high-output piezoelectric horn/transducer, an analog comparator, and a high-current I/O pin that directly drives an LED. The device is uniquely suited for cost-conscious applications such as chemical detectors, alarm systems, and white goods, but can be used in any application that requires high performance and low-power operation. The high-performance 16-bit RISC core and 8-bit accumulators are complemented by standard amenities such as timers and digital I/O. The power consumption per MIPS ratio is among the best in the 16-bit microcontroller industry.

The MAX3210 is powered directly from a 6V–9V source, such as a battery, but an internal voltage regulator operates the core at 5V. The voltage regulator also provides a flag if the input voltage supply falls below 7.5V, which can be used to signal a low-voltage condition of the 9V battery. The MAXQ3212 is a general-purpose version of the MAXQ3210 that is powered directly from an external 5.0V supply.

A 1kWord EEPROM program memory contains customer application code and software algorithms. Software is programmable in-system by the ROM-based bootloader and also in-application programmable under user software control. The device provides 64 bytes of volatile SRAM and 128 bytes of EEPROM in the data memory space. Contact Dallas Semiconductor concerning the availability of ROM-based devices for high-volume, low-cost applications.

### Applications

Gas and Chemical Sensors	Electrochemical and Optical Sensors
Security Alarm Systems	Industrial Control
Environmental Systems	Home Appliances
Battery-Powered and Portable Devices	Thermostats/Humidity Sensors

### Ordering Information

PART	TEMP RANGE	MEMORY	PIN-PACKAGE
MAXQ3210-EJX	-40°C to +85°C	1kWord EEPROM	24 TSSOP
MAXQ3210+EJX	-40°C to +85°C	1kWord EEPROM	24 TSSOP
MAXQ3210-EMX	-40°C to +85°C	1kWord EEPROM	24 PDIP
MAXQ3210+EMX	-40°C to +85°C	1kWord EEPROM	24 PDIP

A "+" denotes a Pb-free/RoHS-compliant device.



### Features

- ◆ **High-Performance, Low-Power, 16-Bit RISC Core**
  - DC to 3.58MHz Operation, Approaching 1MIPS per MHz
  - 6V to 9.5V External Voltage Supply Operates from Single 9V Battery
  - 5.0V Nominal Internal Operation
  - Up to 15 General-Purpose I/O Pins
  - 33 Instructions, Most Single-Cycle
  - Two Independent Data Pointers Accelerate Data Movement with Automatic Increment/Decrement
  - Two Loop Counters
  - 4-Level Hardware Stack
  - 16-Bit Instruction Word, 16-Bit Data Bus
  - 16 x 8-Bit Accumulators
  - 16x16 General-Purpose Working Registers
  - Optimized for C-Compiler (High-Speed/Density Code)
  - JTAG-Like Debug/Visibility Port
- ◆ **Program and Data Memory**
  - 1kWord EEPROM Program Memory, Mask ROM for High-Volume Applications
  - 128 Bytes EEPROM Data Memory
  - 15,000 EEPROM Write/Erase Cycles
  - 64 Bytes SRAM Data Memory
  - In-System Programming
- ◆ **Peripheral Features**
  - Piezoelectric Horn Driver
  - 16-Bit Programmable Timer/Counter with Prescaler
  - High-Current I/O Pin Suitable for LED Drive
  - Programmable Watchdog Timer
  - Selectable Power-Fail Reset
  - Power-On Reset (POR)
  - Wake-Up Timer
  - Internal 4kHz Ring Oscillator
- ◆ **Flexible Programming Interface**
  - Bootloader Simplifies Programming
  - In-System Programming Through JTAG
  - Supports In-Application Programming of EEPROM Memory
- ◆ **Ultra-Low-Power Consumption**
  - <6mA at 3.58MHz
  - 5.5µA Standby Current (typ)
  - Low-Power Divide-by-256 Mode
- ◆ **Analog Features**
  - Analog Comparator Uses Internal or External Voltage Reference
  - +2.5V Reference Output Available
  - On-Chip Voltage Regulator Supports Up to 9V as Power Supply
  - Low-Battery Detection
  - 5V Regulated Output Available, Up to 50mA

# PRELIMINARY PRODUCT REVIEW

## Microcontroller with Internal Voltage Regulator, Piezoelectric Horn Driver, and Comparator

### Functional Diagram

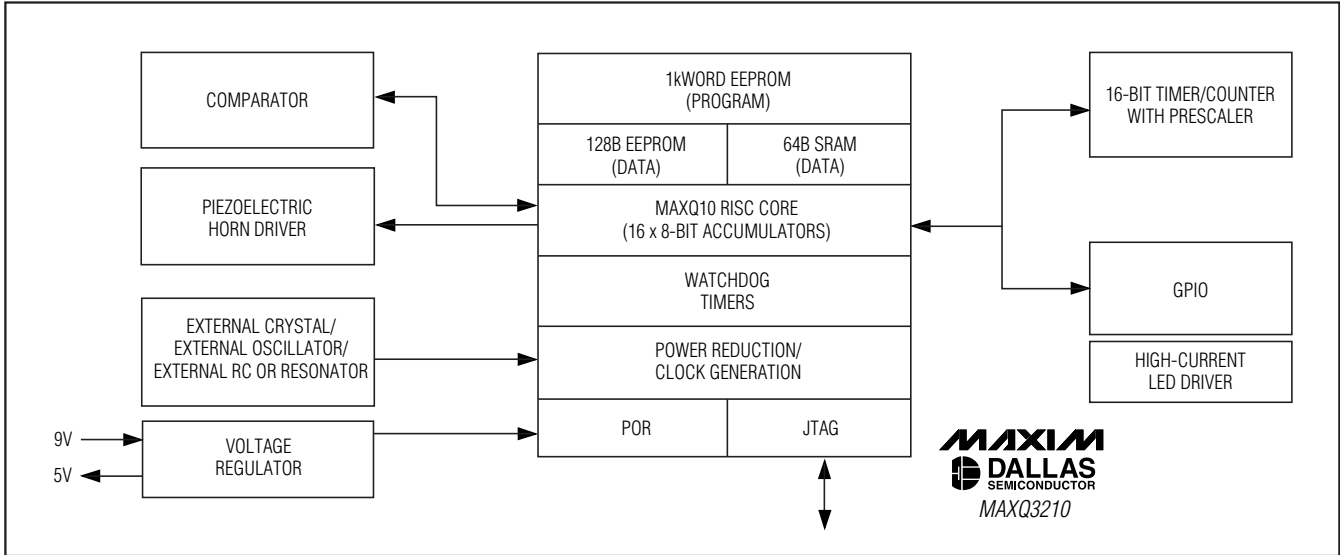

### Typical Operating Circuit

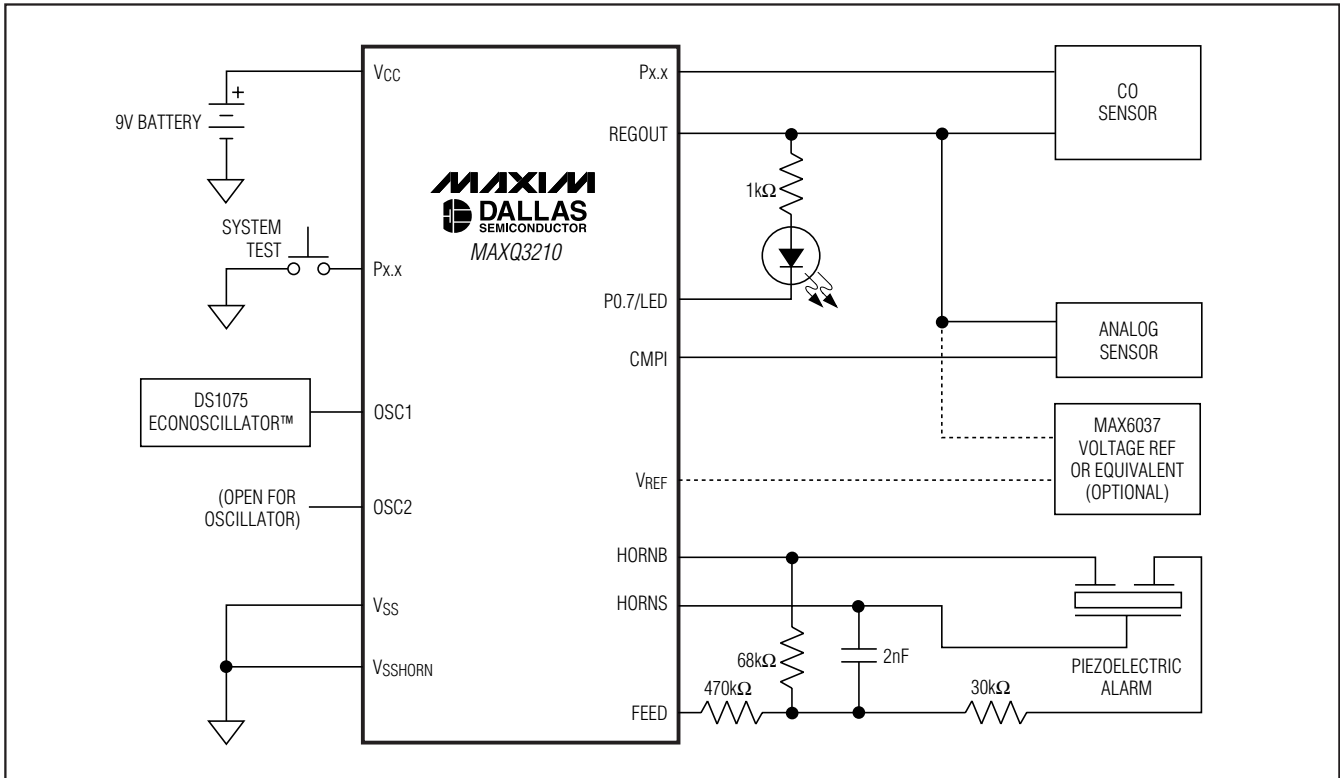

EconOscillator is a trademark of Dallas Semiconductor.